

Cylinder Trolley (Demountable)

The Semmco range of demountable ground servicing trolleys are designed to carry either oxygen or nitrogen cylinders. The units are designed for ease of use in line with occupational health and safety requirements for manual handling of cylinders and can be towed at speeds of up to 25kpm.



Cylinder Trolley (Fixed)

The Semmco range of fixed bed ground servicing trolleys includes models designed to carry 2, 3 or 4 cylinders (MK12 or customer specific) for Oxygen or Nitrogen use. The units are designed to be towed at speeds up to 25kpm.

Nitrogen Servicing Unit (NSU)

The Semmco NSU is a wise, safe and effective alternative for the replacement of up to four multi nitrogen gas cylinder trolleys. Either for commercial or military, Semmco GSE can provide a flexible source of low or high pressure nitrogen gas which can be used for many applications including the filling of tyres, struts and accumulators.



N2 Generation

The modern supply of nitrogen is from a Semmco nitrogen gas generation system providing nitrogen on-site purely at the press of a button, the exact amount required at the exact purity needed and at a fraction of the cost of cylinders. Nitrogen generators take compressed air and pass it through a membrane that absorbs oxygen and other gases to obtain high purity nitrogen gas up to 98%.

Wheel and Brake Service Cart

The Semmco Wheel and Brake Service Cart is designed for road/highway use as well as airport apron and perimeter service roads. This new cart offers the complete service facility for wheel and brake change requirements and is capable of housing two main landing gear wheels, trolley jack and wheel brake dolly.



Jacks

Semmco & HYCOM offer a range of Axle and Trolley Jacks, Tripod Jacks and Tow bars designed and built to withstand harsh environmental conditions, rugged use and to provide many years of continuous service.

Designed to meet the demands and requirements of airlines and maintenance facilities operating narrow/wide body aircraft, regional jets, military aircraft and helicopters.

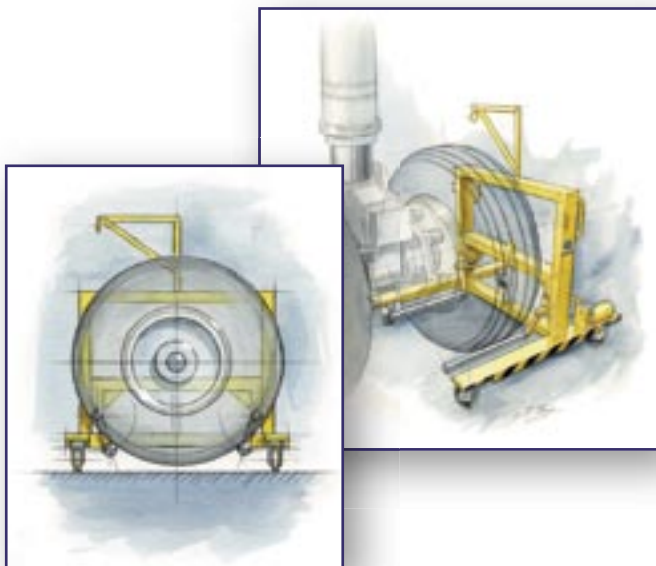

Wheel and Brake Changer

The Semmco Wheel and Brake Changer has been developed for the safe removal and replacement of large aircraft wheels and brake packs.



Access Steps

Semmco and ZACHER have joined forces to supply a range of light weight, compact and variable access and step systems. These modular systems are easily repaired, easily used, are environmentally friendly and safe due to their anti-skid surfacing.



Wheelchair and Galley Cart Lifter

The Semmco Wheelchair and Galley Cart Lifter provides a safe system for lifting wheelchairs and galley carts from ground level to heights up to 3.0 metres (upto 3.5 metres upon customer request). In designing the system the safety of the user and ease of use for the operator have been the prime considerations, IATA compliant.



Refuelling Ladders

Semmco and ZACHER have joined forces to supply a light weight, compact refuelling system. Made from high grade aluminium and built into modular sections, these ladders are quick and easy to repair, easy to use and recyclable. They are also extremely safe due to their antiskid surfacing.